

| | |
|-----------|------------|
| DATA | 19.03.2019 |
| CUSTOMER | |
| REFERENCE | |

| | | | |
|-------------------------|----|-------------------|---|
| Evaporator Model | | P7-70 Ev-F | |
| Number of circuits | | 1 | 1 |
| Requested capacity | kW | 49,85 | |
| Margin | % | 0 | |
| PED category | | --- | |

| INPUT DATA | | PRIMARY SIDE | SECONDARY SIDE |
|-------------------------|----------------------|---------------------|-----------------------|
| Refrigerant | | R407C | |
| Evaporating Temperature | °C | 5 (Dew) | |
| Evaporating Pressure | bar A | 5,469 | |
| Superheating | K | 5 | |
| Condensing Temperature | °C | 45 (Dew) | |
| Condensing Pressure | bar A | 17,536 | |
| Subcooling | K | 5 | |
| Pressure drop | kPa | 39 | |
| Fluid | | | WATER |
| Inlet Temperature | °C | | 15 |
| Outlet Temperature | °C | | 10 |
| Flow rate | m ³ /h | | 8,57 |
| Pressure drop | kPa | | 33,6 |
| Fouling factor | (m ² K)/W | | 0,000043 |
| Velocity (Inside) | m/s | --- | 0,27 |
| Exchange coefficient | W/(m ² K) | 2774 | 8240 |
| DTML | °C | | 7,21 |

WARNING

No warnings

DIMENSIONS

| | | | |
|----------------|-----------------|---------------|-------------------|
| Surface | m ² | 4,9 | |
| Weight | kg | 16 | |
| Channel volume | dm ³ | 4,1 | 4,2 |
| Height | mm | 526 | |
| Width | mm | 120 | |
| Depth | mm | 173,4 | |
| Connections | | ODS 22/ODS 35 | 1.1/4" G/1.1/4" G |

OFFER

| | | |
|----------------|------|--|
| Unit net price | Euro | |
|----------------|------|--|

NOTES

| |
|--|
| |
|--|

| | |
|-----------|------------|
| DATA | 19.03.2019 |
| CUSTOMER | |
| REFERENCE | |

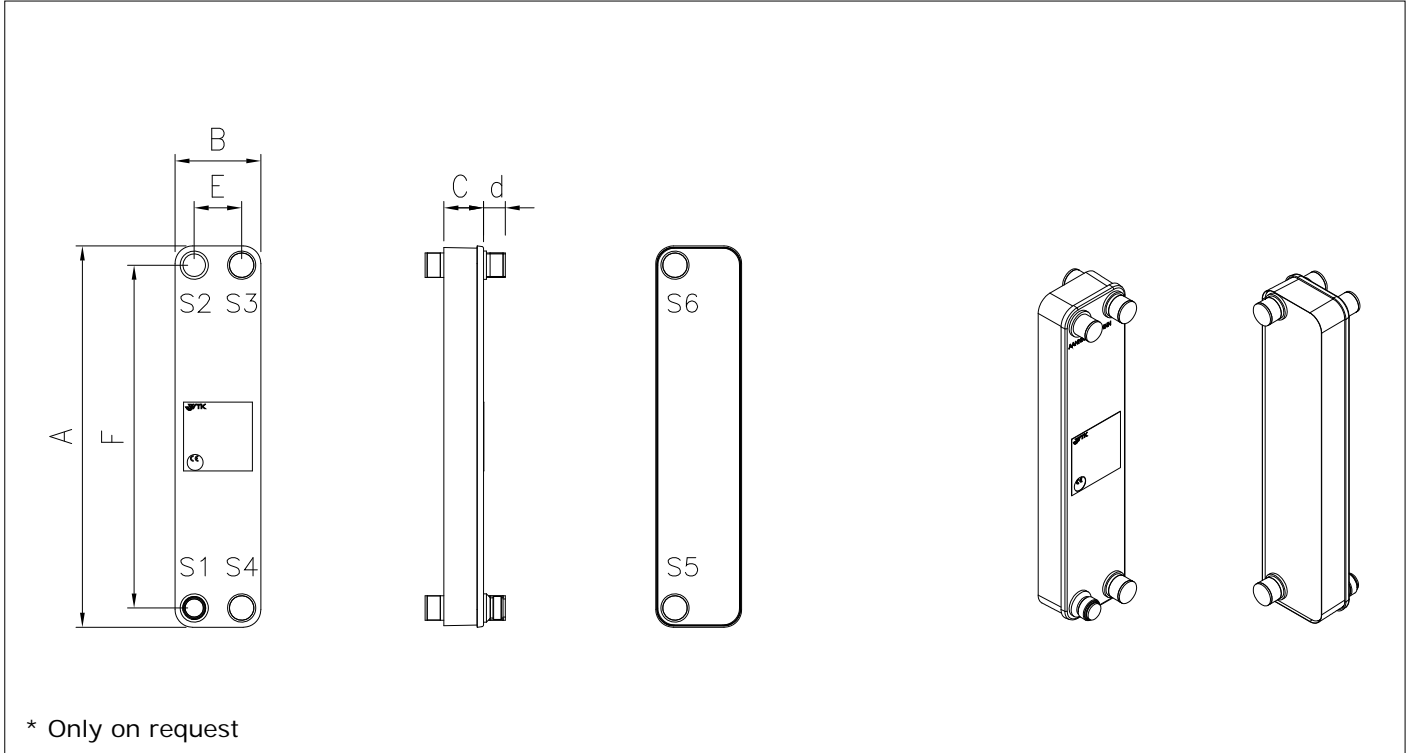
DRAWING

DIMENSIONS (mm)
DATA

| | | | | | | |
|---|-------|-----|----------|---------|----|-----|
| A | 526 | S1 | ODS 22 | Surface | m? | 4,9 |
| B | 120 | S2 | ODS 35 | Weight | kg | 16 |
| C | 173,4 | S3 | 1.1/4" G | | | |
| E | 66 | S4 | 1.1/4" G | | | |
| F | 473 | S5* | 1.1/4" G | | | |
| G | -- | S6* | 1.1/4" G | | | |
| d | 27 | S7 | -- | | | |
| | | S8 | -- | | | |
| | | | | | | |

This software is only to be used as an assistance and does not replace the necessary specialist knowledge and experience when designing heat exchangers. We continuously work in order to improve and correct the software. Nevertheless we cannot guarantee its absolute infallibility. Therefore the use of the program is at the user's risk.