

DATA	19.03.2019
CUSTOMER	
REFERENCE	

Evaporator Model		P7-30 Ev-F	
Number of circuits		1	1
Requested capacity	kW	22,50	
Margin	%	0	
PED category		---	

INPUT DATA		PRIMARY SIDE	SECONDARY SIDE
Refrigerant		R407C	
Evaporating Temperature	°C	5 (Dew)	
Evaporating Pressure	bar A	5,469	
Superheating	K	5	
Condensing Temperature	°C	45 (Dew)	
Condensing Pressure	bar A	17,536	
Subcooling	K	5	
Pressure drop	kPa	29	
Fluid			WATER
Inlet Temperature	°C		15
Outlet Temperature	°C		10
Flow rate	m ³ /h		3,87
Pressure drop	kPa		31,2
Fouling factor	(m ² K)/W		0,000043
<i>Velocity (Inside)</i>	<i>m/s</i>	---	<i>0,28</i>
<i>Exchange coefficient</i>	<i>W/(m² K)</i>	<i>3086</i>	<i>8528</i>
<i>DTML</i>	°C		<i>7,21</i>

WARNING

No warnings

DIMENSIONS

Surface	m ²	2,100	
Weight	kg	8	
Channel volume	dm ³	1,7	1,8
Height	mm	526	
Width	mm	120	
Depth	mm	77,4	
Connections		ODS 22/ODS 35	1.1/4" G/1.1/4" G

OFFER

Unit net price	Euro	
----------------	------	--

NOTES

--	--	--

DATA	19.03.2019
CUSTOMER	
REFERENCE	

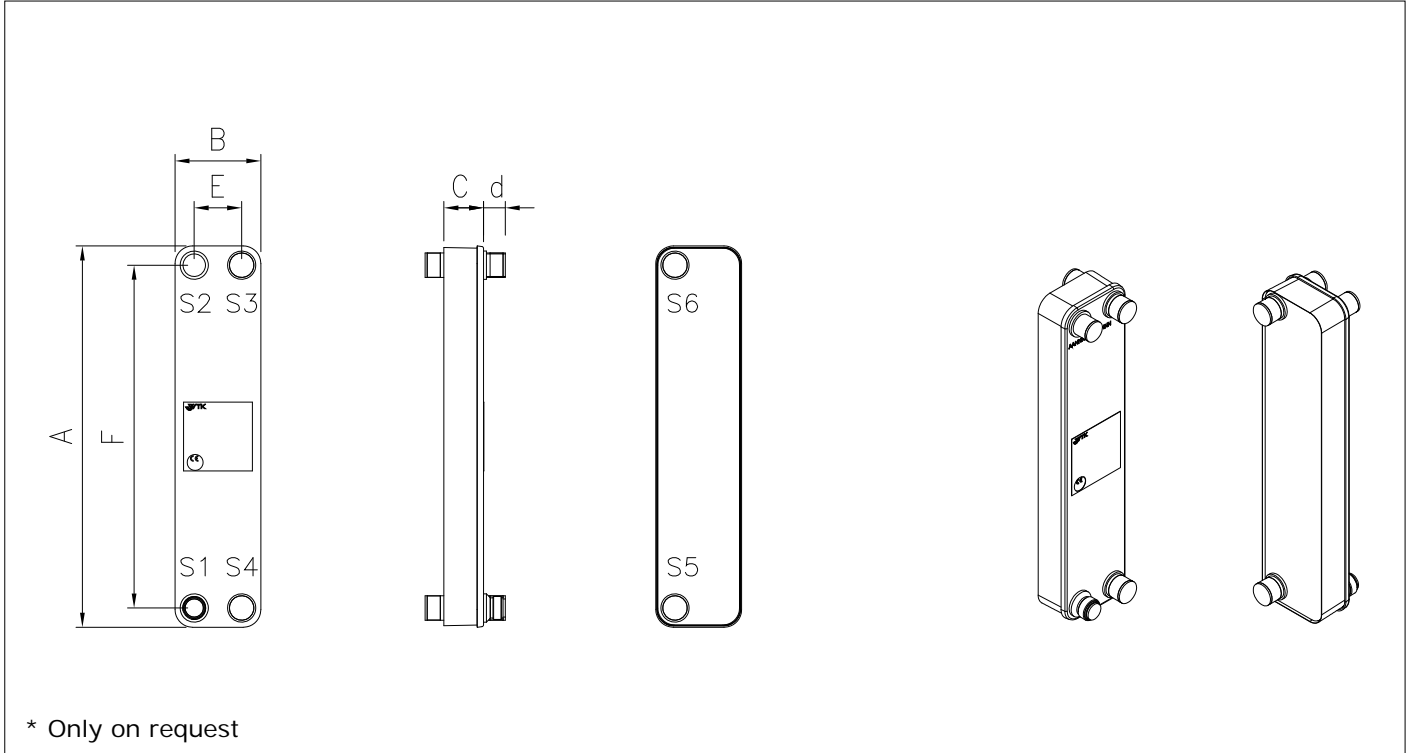
DRAWING

DIMENSIONS (mm)
DATA

A	526	S1	ODS 22	Surface	m?	2,100
B	120	S2	ODS 35	Weight	kg	8
C	77,4	S3	1.1/4" G			
E	66	S4	1.1/4" G			
F	473	S5*	1.1/4" G			
G	--	S6*	1.1/4" G			
d	27	S7	--			
		S8	--			

This software is only to be used as an assistance and does not replace the necessary specialist knowledge and experience when designing heat exchangers. We continuously work in order to improve and correct the software. Nevertheless we cannot guarantee its absolute infallibility. Therefore the use of the program is at the user's risk.