

DATA	20.03.2019
CUSTOMER	
REFERENCE	

Evaporator Model		P12-20 Ev-F	
Number of circuits		1	1
Requested capacity	kW	41,14	
Margin	%	0	
PED category		---	

INPUT DATA		PRIMARY SIDE	SECONDARY SIDE
Refrigerant		R407C	
Evaporating Temperature	°C	5 (Dew)	
Evaporating Pressure	bar A	5,469	
Superheating	K	5	
Condensing Temperature	°C	45 (Dew)	
Condensing Pressure	bar A	17,536	
Subcooling	K	5	
Pressure drop	kPa	57	
Fluid			WATER
Inlet Temperature	°C		15
Outlet Temperature	°C		10
Flow rate	m ³ /h		7,07
Pressure drop	kPa		98,5
Fouling factor	(m ² K)/W		0,000043
Velocity (Inside)	m/s	---	0,52
Exchange coefficient	W/(m ² K)	9482	13700
DTML	°C		7,21

WARNING

Pressure drops water side higher than allowed limits.

DIMENSIONS

Surface	m ²	2,400	
Weight	kg	15	
Channel volume	dm ³	3,4	3,8
Height	mm	617	
Width	mm	188	
Depth	mm	55,3	
Connections		ODS 28/ODS 54	2" G/2" G

OFFER

Unit net price	Euro	
----------------	------	--

NOTES

--

DATA	20.03.2019
CUSTOMER	
REFERENCE	

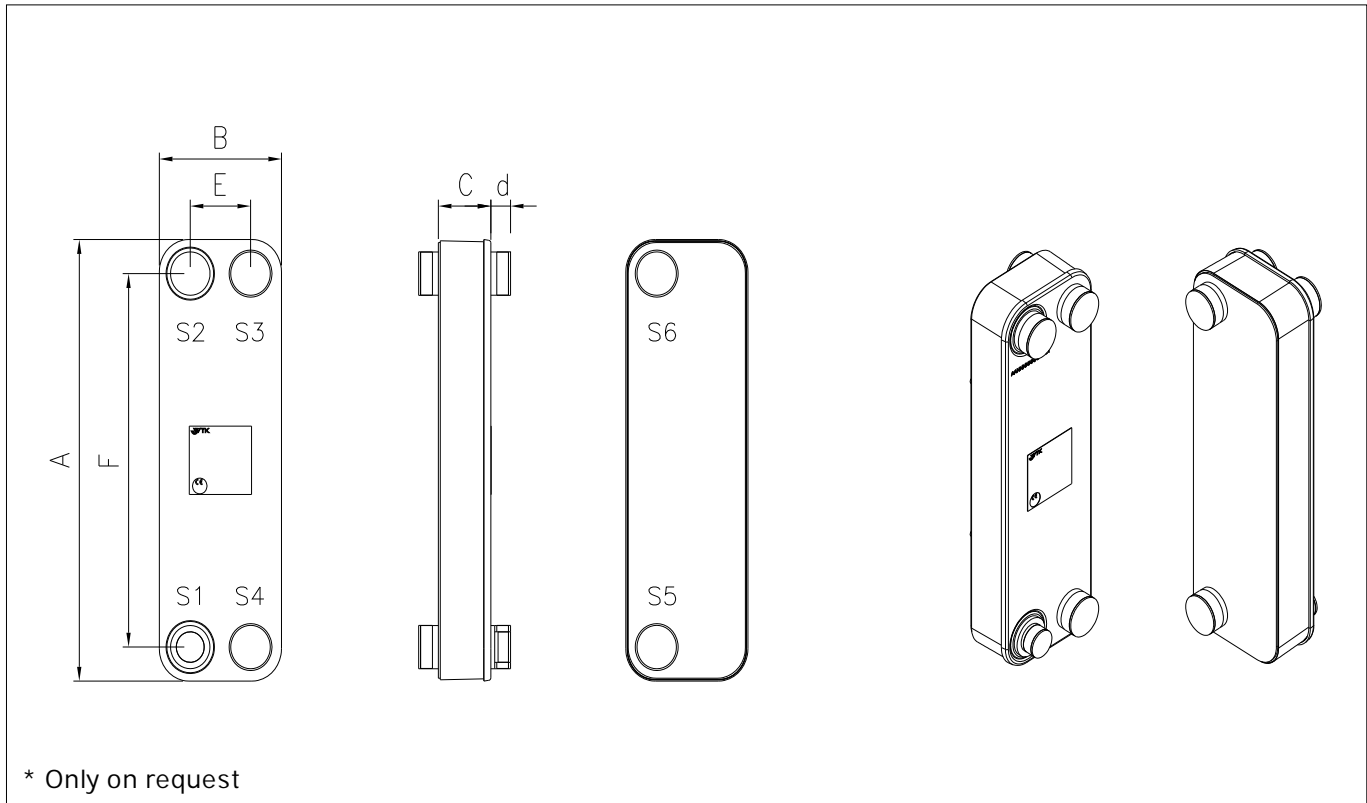
DRAWING

DIMENSIONS (mm)
DATA

A	617	S1	ODS 28	Surface	m?	2,400
B	188	S2	ODS 54	Weight	kg	15
C	55,3	S3	2" G			
E	92	S4	2" G			
F	519	S5*	2" G			
G	--	S6*	2" G			
d	27	S7	--			
		S8	--			

This software is only to be used as an assistance and does not replace the necessary specialist knowledge and experience when designing heat exchangers. We continuously work in order to improve and correct the software. Nevertheless we cannot guarantee its absolute infallibility. Therefore the use of the program is at the user's risk.